



REL

REL
ACOUSTICS LTD



Operating Instructions for the

Planar-Cart Accessory

Stability & Anti-Tip Safety

Planar is designed to be mounted to a wall or used in close relationship with a wall for optimal performance. When used in a freestanding position, it may tip if subjected to sufficient force.

REL strongly recommends installing the included anti-tip restraint in all freestanding applications, especially in environments with children, pets, or high foot traffic.

Installing the Anti-Tip Restraint

The Anti-Tip Restraint is comprised of a wall tether block that will mount onto the back of your Planar subwoofer's cabinet, hardware that will screw into your wall, and a tether that will anchor these pieces together. For safe operation when Planar is used in a freestanding position, install the included anti-tip restraint as follows:

- 1 Secure the wall tether block to the subwoofer's cabinet, using the supplied bolts. This block and the bolts are designed to mount to the center and upper-right inserts found on the rear face of the Planar subwoofer's cabinet. See *Cart Drawing 5*.
- 2 Secure the two included loose anchors to your wall. Each anchor uses two screws for securing to the wall. We recommend marking the screw locations with a pencil, drilling pilot holes using a 6mm drill bit, then pressing the plastic drywall anchors into the pilot holes. You can then screw in the metal anchors.
- 3 Once the anchors are installed onto your wall and the tether block is installed onto the subwoofer, you can use the two supplied cables for securing each anchor on the block to the corresponding anchor on your wall. See *Cart Drawing 6*.

Inspect the anti-tip restraint periodically to confirm it remains securely attached.

Use of the anti-tip restraint is the primary method of preventing tip-over when Planar is used in a freestanding position.

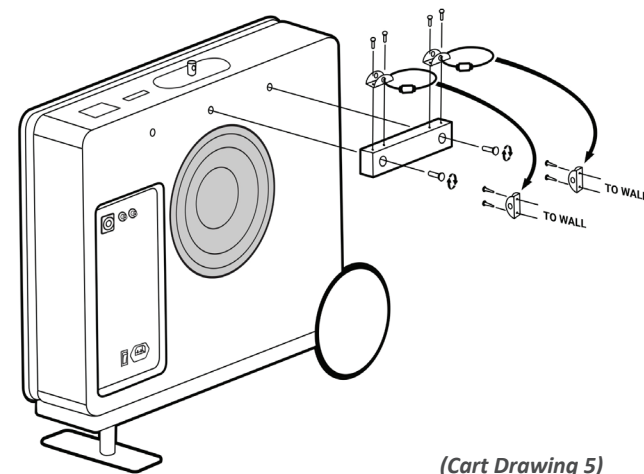

(Cart Drawing 5)

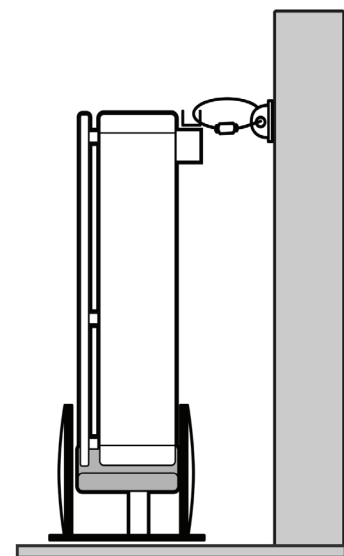

(Cart Drawing 6)

Instructions for Planar Cart-1 and Planar Cart-2

IMPORTANT SAFETY WARNING

When Planar is not mounted to a wall, it may tip if subjected to force, impact, or climbing. This applies to any freestanding use, including use with the accessory stand (Cart).

To reduce the risk of tip-over, an anti-tip restraint system is included. REL strongly recommends installing this restraint in all freestanding applications.

Failure to install the restraint may result in injury or damage.

Do not allow children to climb, hang, or pull on the product.

Instructions for Installing Planar Cart-1 or Planar Cart-2:

Note: *Planar Cart is not a toy. Its wheels move slowly, in part to discourage running around with it. It is a precision tool designed to allow precise location of, and placement on, deep bass nodes that are the key to obtaining the performance that your Planar is capable of delivering.*

1 First, prepare your work area. Set out the necessary tools and hardware (hex wrench and bolts, supplied with Cart) and lay a soft, clean cloth or blanket for the subwoofer to rest on. At this time, install the subwoofer's grille if you intend to use it, as it cannot be installed once the Cart is attached. Make sure the control panel top cover has been removed, as turning your Planar upside down will result in the cover falling out and possibly incurring damage.

2 Fully power off the subwoofer, then carefully turn the subwoofer over so that it is sitting upside down on the soft cloth or blanket. You will then see three (3) holes with threaded inserts in the bottom of the subwoofer's cabinet. See *Cart Drawing 1*.

3 Carefully place the cart so that the soft damping material is resting on the bottom of the subwoofer's cabinet, and the holes in the Cart are aligned with the threaded inserts in the bottom of the cabinet.

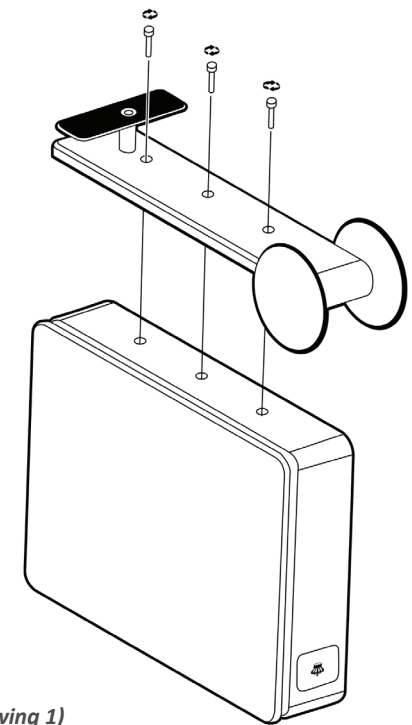

(Cart Drawing 1)

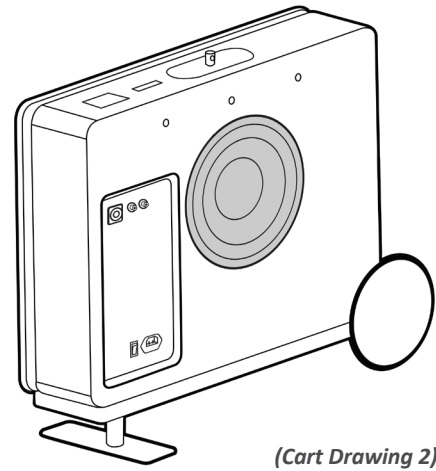

(Cart Drawing 2)

4 Using the supplied hex wrench, insert and tighten the three supplied bolts so they are hand-tight. Use the supplied allen key to snug the bolts down. Please take care not to over-tighten or apply too much torque to these bolts.

5 Once the bolts are snugged down, carefully turn the subwoofer's cabinet over so that it is resting on the Cart, with the two wheels and front stabilizer resting on the floor. See *Cart Drawing 2*.

6 Next, please screw the handle into the upper-left threaded insert on the rear of the subwoofer's cabinet. This will result in the handle being diagonally opposite from the Cart's wheels. See *Cart Drawing 3*.

7 Using the handle, carefully elevate the subwoofer so that the front stabilizer lifts off the floor, and then carefully position the Planar subwoofer and Cart in the desired location in your room. The end of the handle that will be closest to the wall has a soft foam ball, which is to be used to locate the subwoofer at the appropriate distance from your wall.

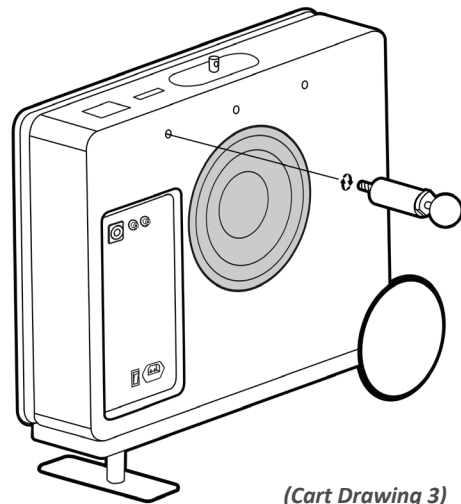

(Cart Drawing 3)

Warnings/Things to Note:

- We strongly recommend placing a soft cloth or blanket on your work surface prior to rotating the subwoofer or installing the Cart. This will help to preserve the subwoofer's gloss lacquer finish.
- Be sure to power off the subwoofer and disconnect the power cord prior to installing the Cart.
- Secure the mounting bolts and handle tightly to the subwoofer's cabinet, though be sure not to over-tighten these bolts or the handle. Hand-tight will be sufficient.
- The Cart is designed to improve mobility and positioning of the subwoofer in the event that Planar subwoofer is not mounted on a wall. However, the Cart's wheels are not designed or intended for excessive use.

Directions for Setup and Placement When Using Planar Cart

The Planar cart is both a clever piece of design and a calibration tool. It is designed to allow precise location of the deep bass nodes that determine where to place a movable floor-mounted Planar to derive maximum performance.

Note: We recommend using track 4 from the CD soundtrack to the 1992 movie *Sneakers* (titled *Cosmo... Old Friend*) which features a deeply tuned concert bass drum that is struck with precision and almost identical force to produce a deep bass signal that delivers consistent dynamics. It is possible to achieve perfect phase response and crossover settings using this simple mechanism of slow movement and careful listening.

Note: The cart is specifically designed not to roll freely because moving a subwoofer quickly guarantees missing the seemingly minor, but important bass pulses that signal spots in the room that produce deeper, cleaner bass.

1 Begin by gently rolling the cart into the general area of your selected wall that you wish to have it perform. Line it up carefully parallel to the wall about 2-3" (50-75mm) further way from the wall than the tip of the foam ball at the end of the handle. This extra space will make it easier for you to maneuver.

2 While playing this setup track moderately loud, begin slowly drawing the cart-mounted Planar parallel to the wall by lifting up the front of the cart and pulling the handle. Be prepared to stop instantly, set down the Planar, and mark locations where bass appears to jump up in level (a small coin or piece of tape next to the outer wheel works well). Assess each location that is marked for depth of bass, firmness of pulse, and the subjective qualities of clarity and fullness. Make your best choice among the 3-4 such locations that will work for the way your room lays out. If one side of the front wall is not working optimally, switch to the other side of the room. If the front wall doesn't produce the depth or quality of bass, select another wall. Leave your marker in place and be careful not to disturb it. Precision of placement means knowing where the bass response will produce the best results.

3 Once you have decided on your ideal location, pull your Planar a few inches forward and turn it toward the room's center. By this point it should be about 1' (30cm) past and toed noticeably inward toward the room's centerline. Now "parallel park" your planar, so that it is parallel with the wall. The outer wheel of the Cart should be aligned with your marker on the floor, and the foam ball end of the handle should be just barely making contact with your wall. Make any final small adjustments to get it aligned with the exact point on your marker and then fine tune crossover and level settings to give optimal results. Remember, the rule of thumb is that Level should, in most instances, be a higher click count than your Crossover setting. See *Cart Drawing 4*.

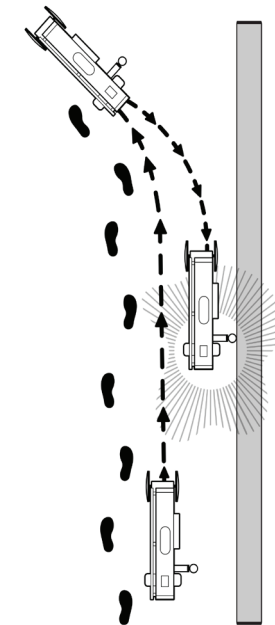

(Cart Drawing 4)